

Kcal = Watt x 0.860  
BTU = Watt x 3.413

Watt  $\Delta t$  60° = Watt  $\Delta t$  50° x 1.264  
Watt  $\Delta t$  40° = Watt  $\Delta t$  50° x 0.750  
Watt  $\Delta t$  30° = Watt  $\Delta t$  50° x 0.517  
Watt  $\Delta t$  20° = Watt  $\Delta t$  50° x 0.307

p max = 5.0 bar

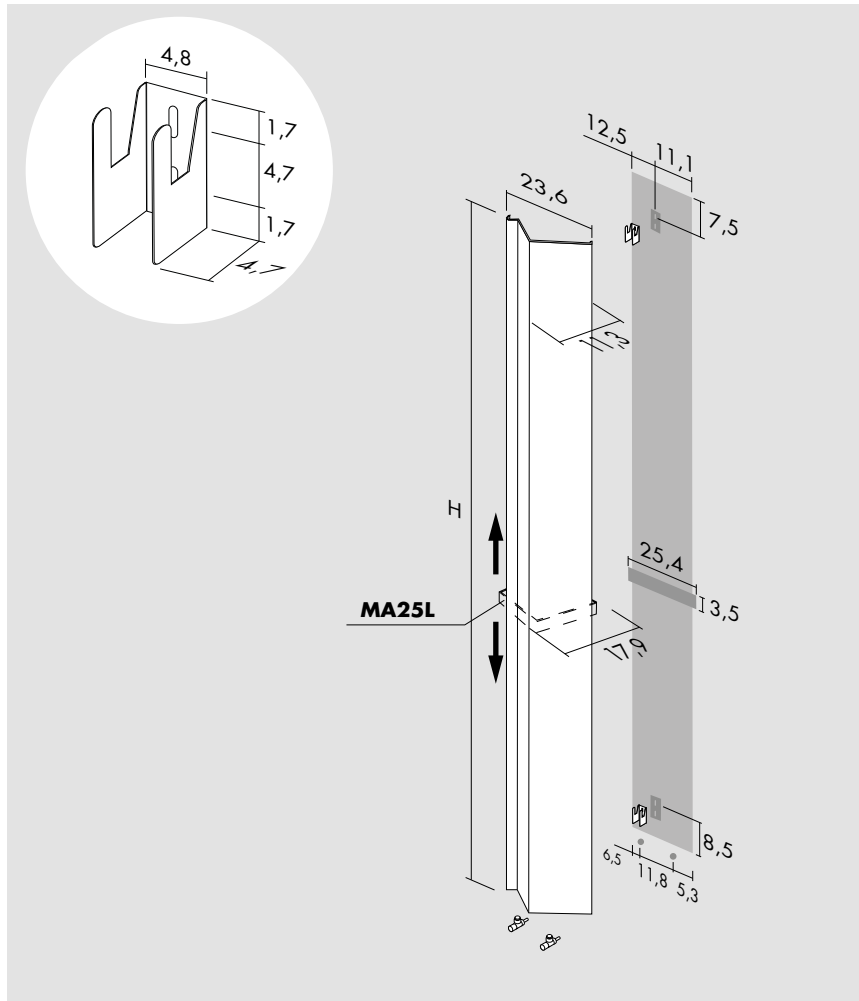

## [F]

Standard connection / Raccord standard  
Standard Anschluss / Conexión estándar

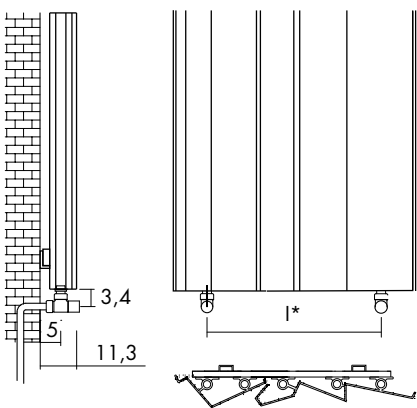

## [H]

Special connection / Raccord spéciale / Speziell Anschluss / Conexión especial

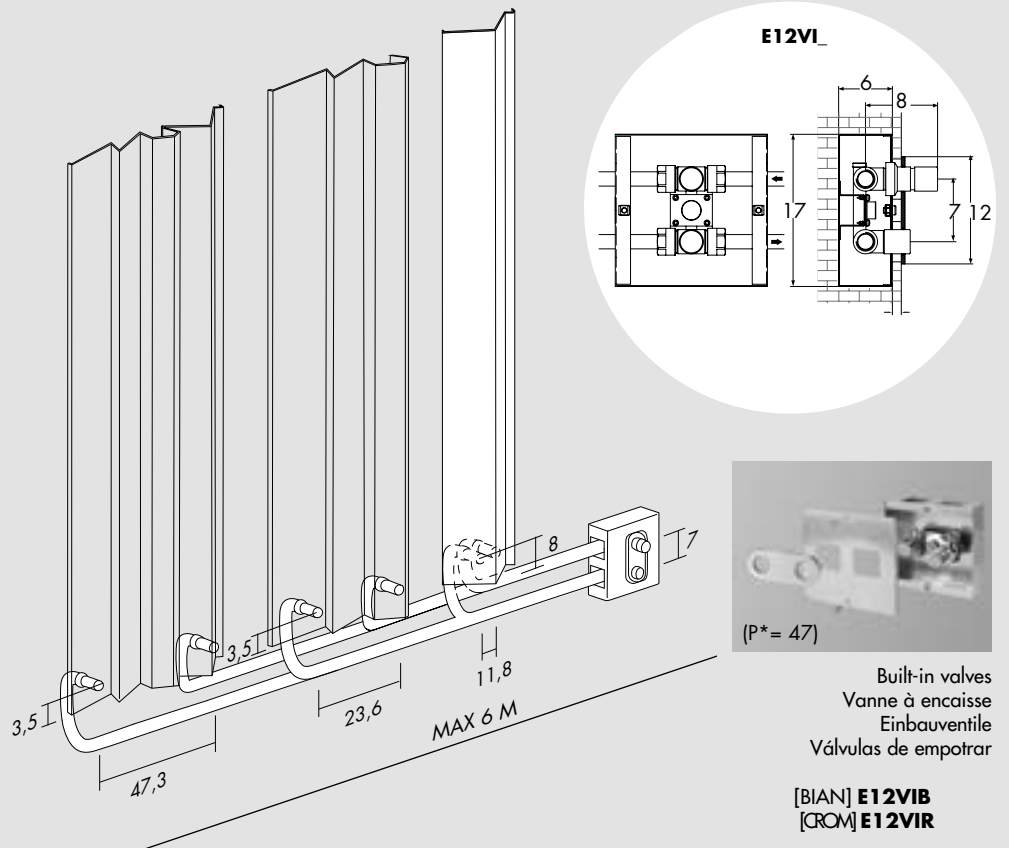

Built-in valves  
Vanne à encaisse  
Einbauventile  
Válvulas de empotrar

[BIAN] E12VIB  
[CROM] E12VIR

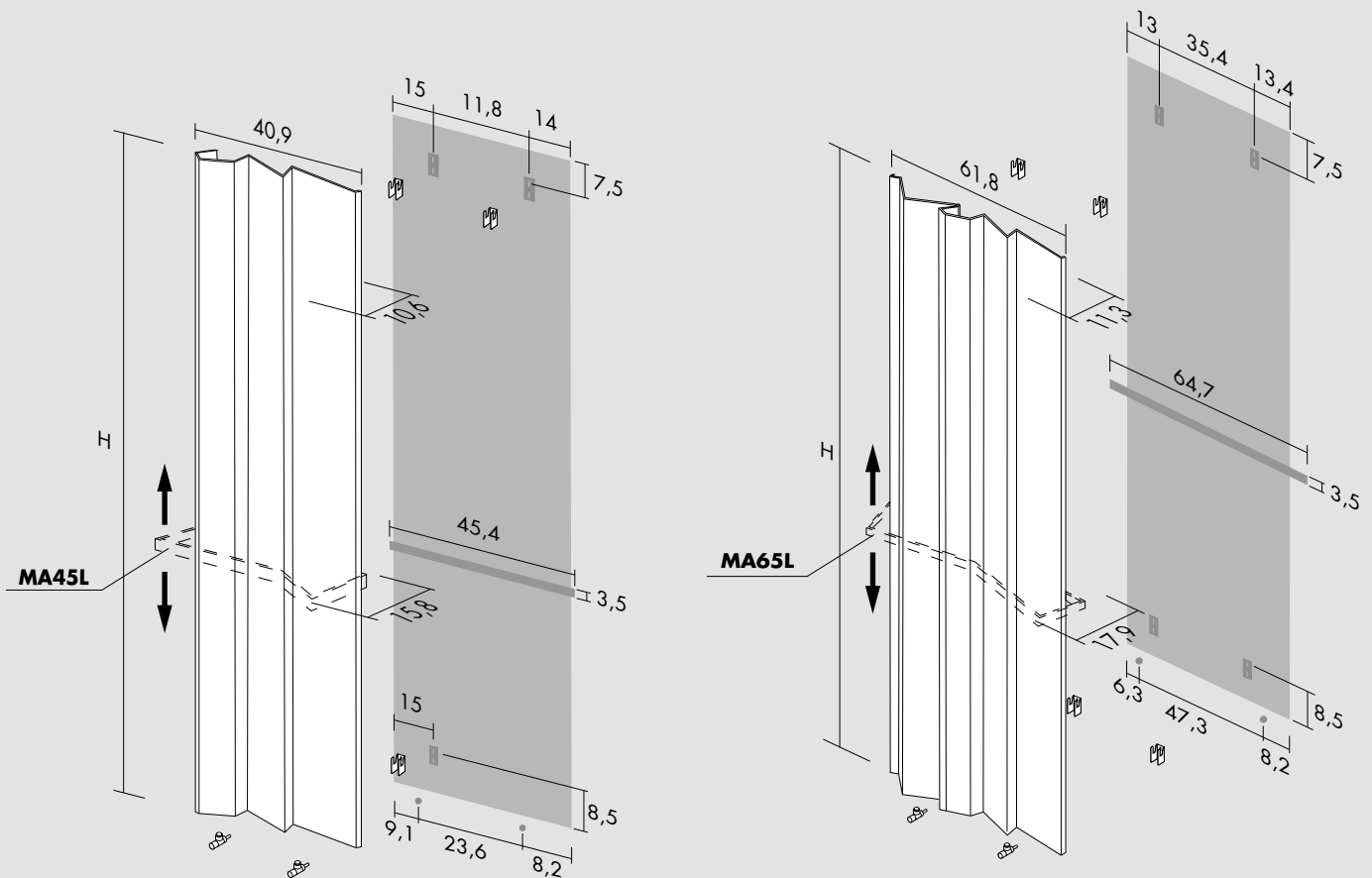

## Android V

H cm	L cm	I* cm	art*	Lt*	watt $\Delta t$ 30°	watt $\Delta t$ 50°
150.0	23.6	11.8	<b>ANDV150023</b>	0.9	240	<b>464</b>
150.0	40.9	23.6	<b>ANDV150040</b>	1.5	384	<b>742</b>
150.0	61.8	47.3	<b>ANDV150061</b>	2.5	596	<b>1 153</b>
180.0	23.6	11.8	<b>ANDV180023</b>	1.0	283	<b>547</b>
180.0	40.9	23.6	<b>ANDV180040</b>	1.8	452	<b>875</b>
180.0	61.8	47.3	<b>ANDV180061</b>	2.9	703	<b>1 360</b>
200.0	23.6	11.8	<b>ANDV200023</b>	1.2	312	<b>603</b>
200.0	40.9	23.6	<b>ANDV200040</b>	1.9	498	<b>964</b>
200.0	61.8	47.3	<b>ANDV200061</b>	3.3	775	<b>1 499</b>

## Optional



(P\* = 46)

Angled Valve  
 Robinet équerre  
 Eckausführung Ventil  
 Válvula a escuadra

[BIAN] **E125QB**  
 [CROM] **E125QR**



(P\* = 47)

Thermostatic head  
 Tête thermostatique  
 Thermostatkopf  
 Cabezal termostático

[BIAN] **TTB**  
 [CROM] **TTR**

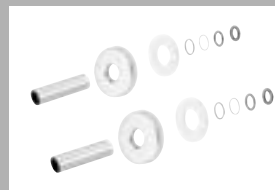

$\varnothing \leq 16$  mm  
 [BIAN] **CTB**  
 [CROM] **CTR**

$16 \text{ mm} < \varnothing > 24 \text{ mm}$   
 [BIAN] **CWB**  
 [CROM] **CWR**



25,4 cm  
 [XLUC] **MA25L**  
 45,4 cm  
 [XLUC] **MA45L**  
 64,7 cm  
 [XLUC] **MA65L**

Kcal= Watt x 0.860  
 BTU= Watt x 3.413

Watt  $\Delta t$  60° = Watt  $\Delta t$  50° x 1.257  
 Watt  $\Delta t$  40° = Watt  $\Delta t$  50° x 0.755  
 Watt  $\Delta t$  30° = Watt  $\Delta t$  50° x 0.526  
 Watt  $\Delta t$  20° = Watt  $\Delta t$  50° x 0.316

p max = 5.0 bar

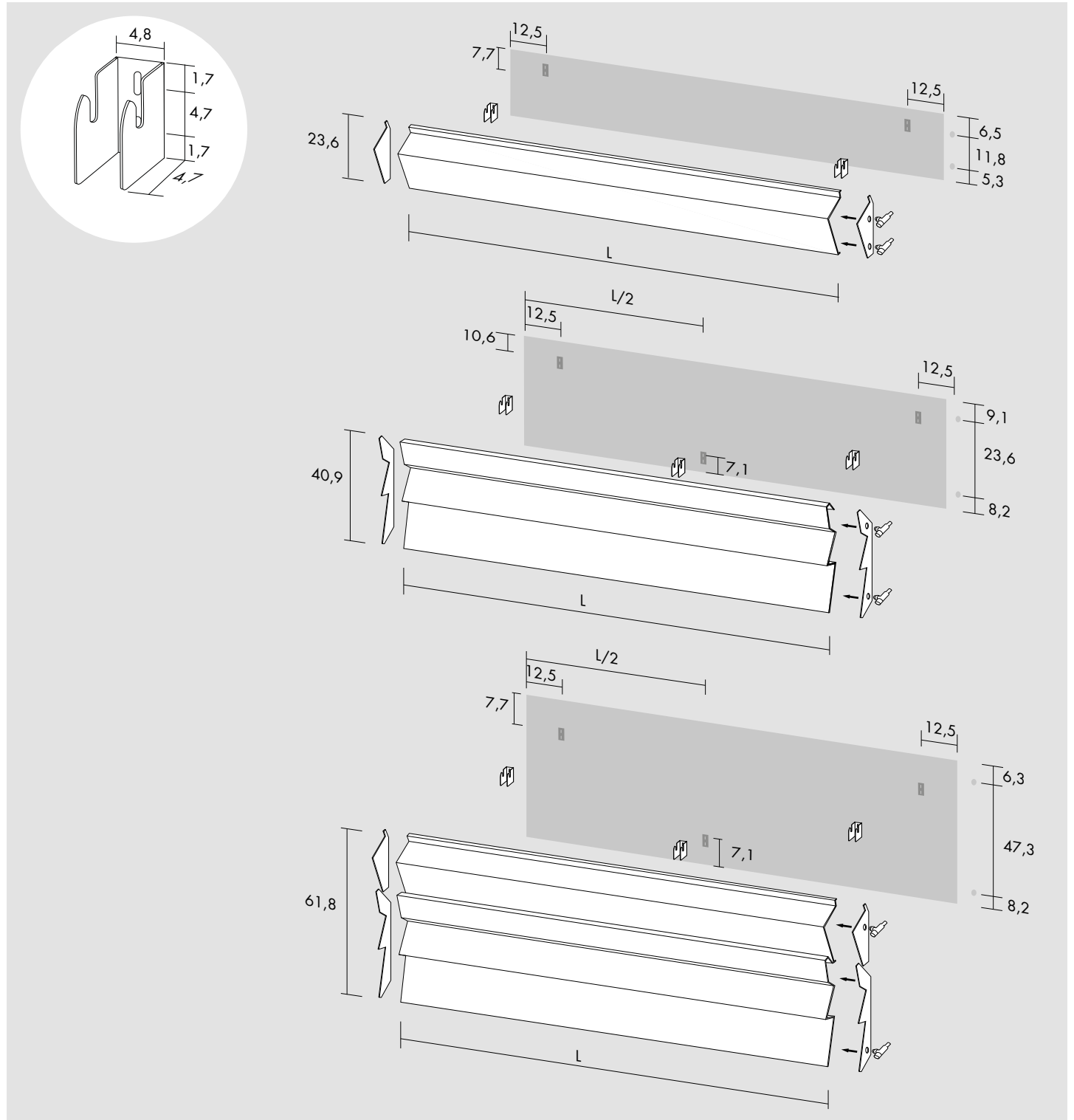

[F]

Standard connection / Raccord standard  
 Standard Anschluss / Conexión estándar

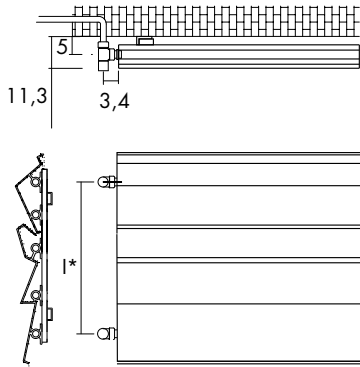

[H]

Special connection / Raccord spéciale / Speziell Anschluss / Conexión especial

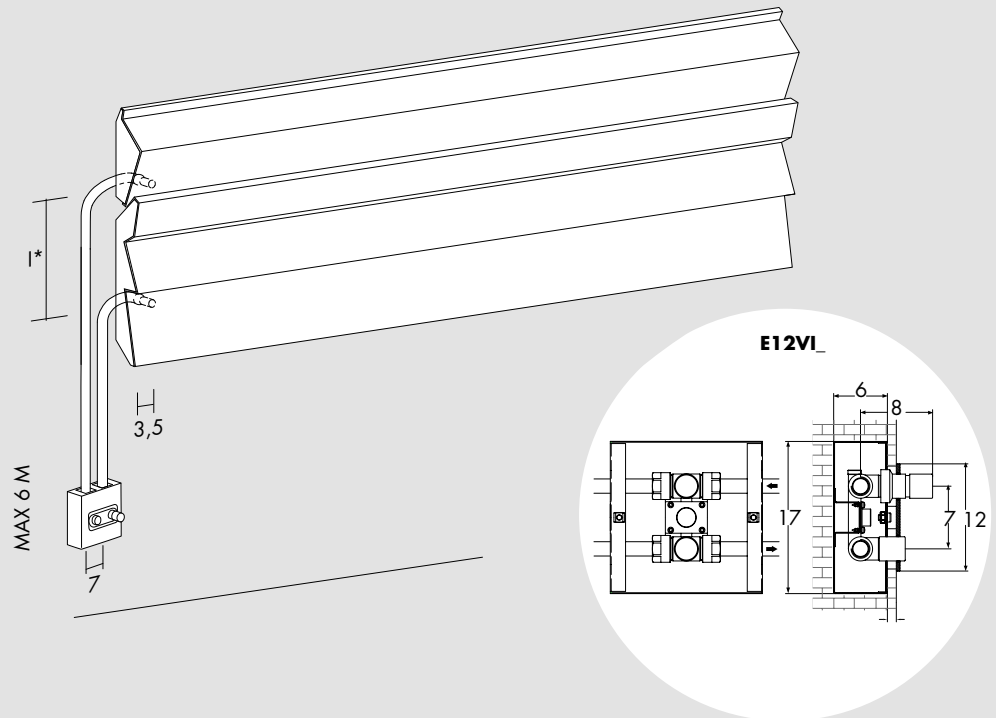

[FS]

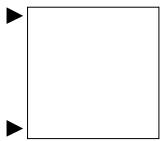

[FD]

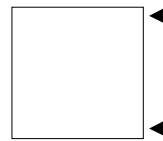

[HS]

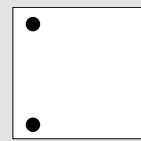

[HD]

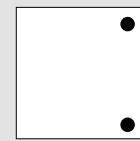

Built-in valves  
 Vanne à encaisse  
 Einbauventile  
 Válvulas de empotrar

[BIAN] E12VIB  
 [CROM] E12VIR

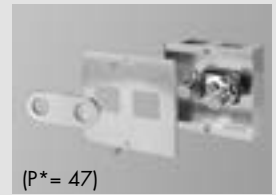

Android O

H cm	L cm	I* cm	art*	Lt*	watt $\Delta t$ 30°	watt $\Delta t$ 50°
23.6	150.0	11.8	ANDO150023_	0.9	224	426
40.9	150.0	23.6	ANDO150040_	1.5	359	682
61.8	150.0	47.3	ANDO150061_	2.5	544	1 034
23.6	180.0	11.8	ANDO180023_	1.1	269	512
40.9	180.0	23.6	ANDO180040_	1.8	430	818
61.8	180.0	47.3	ANDO180061_	3.0	653	1 241
23.6	200.0	11.8	ANDO200023_	1.2	299	569
40.9	200.0	23.6	ANDO200040_	1.2	478	909
61.8	200.0	47.3	ANDO200061_	3.3	725	1 379

Optional



Angled Valve  
 Robinet équerre  
 Eckausführung Ventil  
 Válvula a escuadra

[BIAN] E12SQB  
 [CROM] E12SQR



Thermostatic head  
 Tête thermostatique  
 Thermostatkopf  
 Cabezal termostático

[BIAN] TTB  
 [CROM] TTR

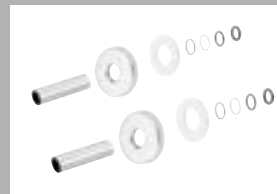

$\varnothing \leq 16$  mm  
 [BIAN] CTB  
 [CROM] CTR

$16$  mm  $< \varnothing > 24$  mm  
 [BIAN] CWB  
 [CROM] CWR

art\* = item / modèle / Artikel / artículo    I\* = pipe centres / distance entre depart et retour / Achsabstand / distancia entre las conexiones  
 Lt\* = water content for each element / volume d'eau pour chaque element / Wassergehalt für Element / contenido de agua por cada elemento  
 P\* = page / page / Seite / página

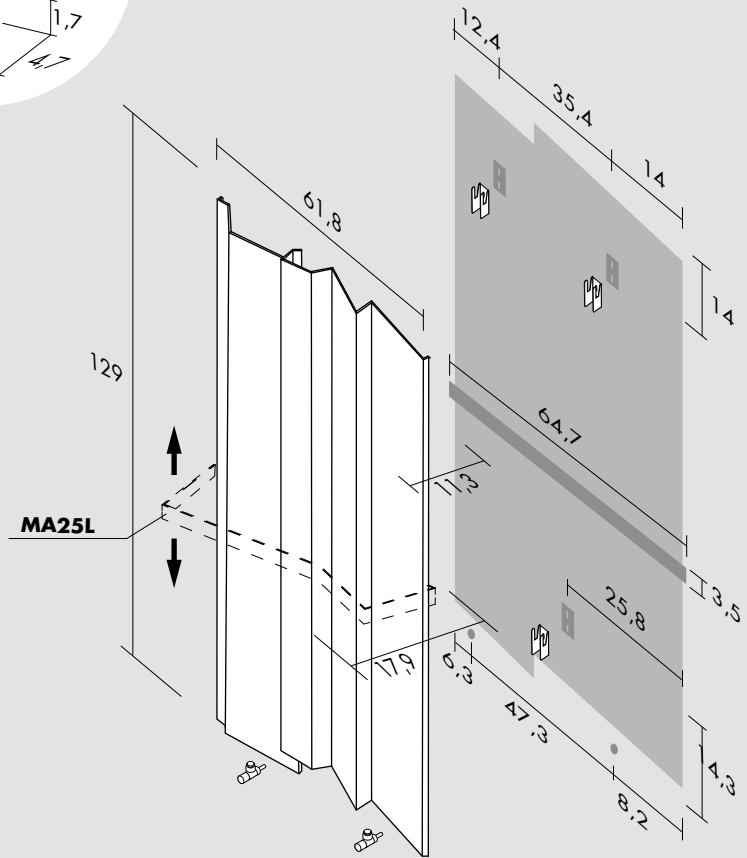
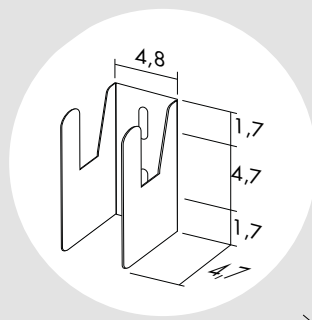

Kcal = Watt x 0.860  
 BTU = Watt x 3.413

Watt  $\Delta t$  60° = Watt  $\Delta t$  50° x 1.264  
 Watt  $\Delta t$  40° = Watt  $\Delta t$  50° x 0.750  
 Watt  $\Delta t$  30° = Watt  $\Delta t$  50° x 0.517  
 Watt  $\Delta t$  20° = Watt  $\Delta t$  50° x 0.307

p max = 5.0 bar

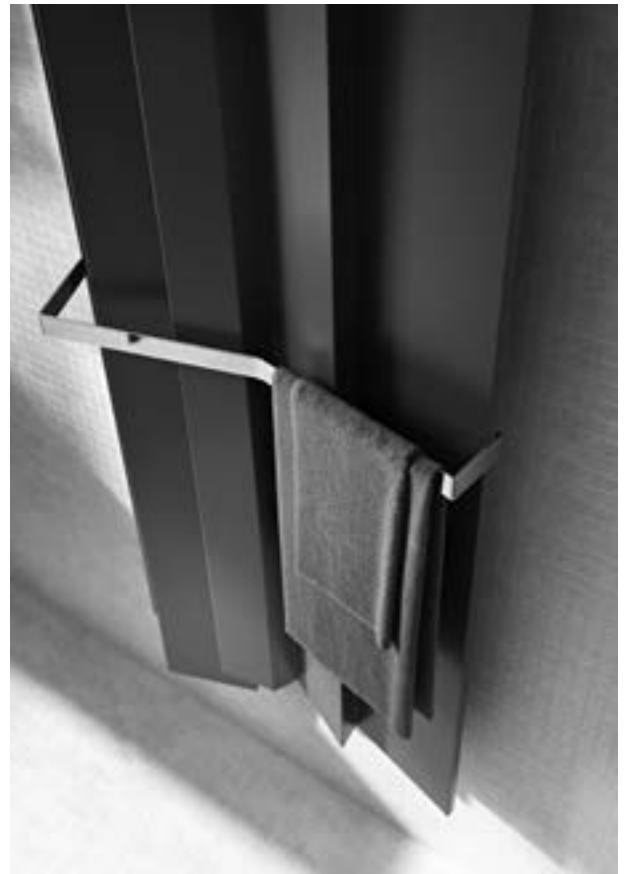

[F]

Standard connection / Raccord standard  
 Standard Anschluss / Conexión estándar

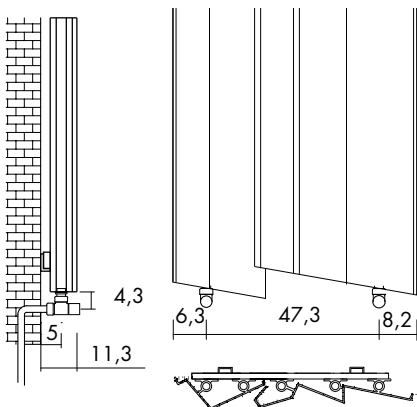

[H]

Special connection / Raccord spéciale / Speziell Anschluss / Conexión especial

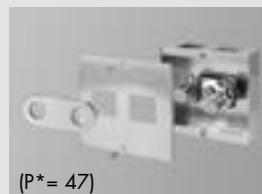
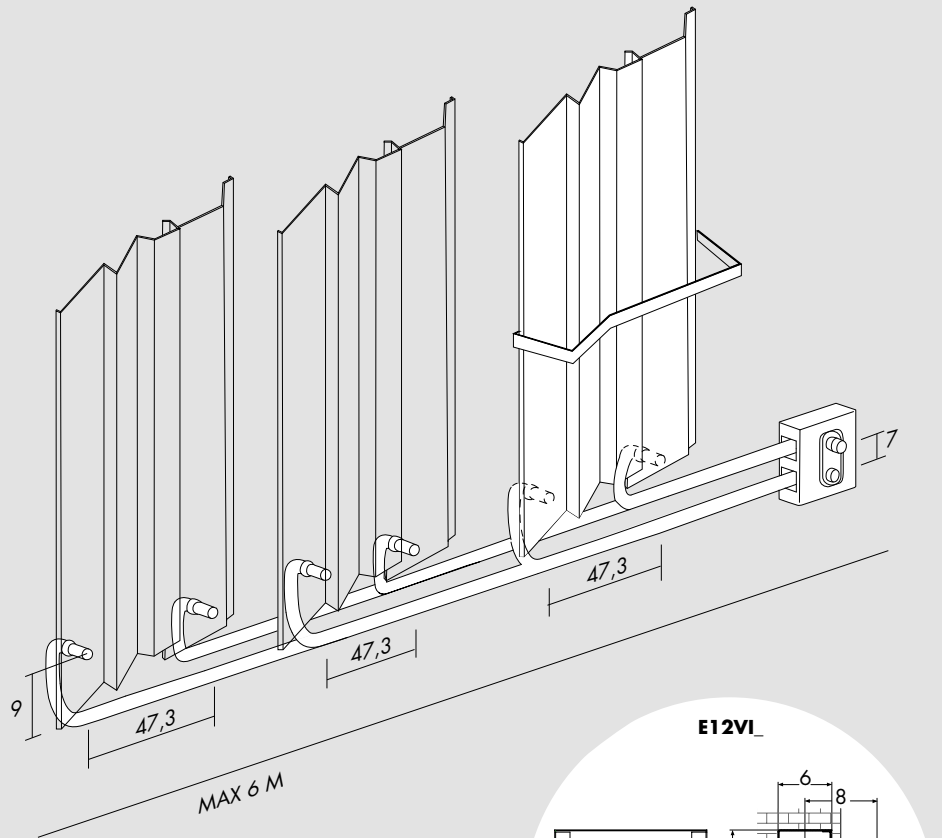

Built-in valves  
 Vanne à encaisse  
 Einbauventile  
 Válvulas de empotrar

[BIAN] **E12VIB**  
 [CROM] **E12VIR**

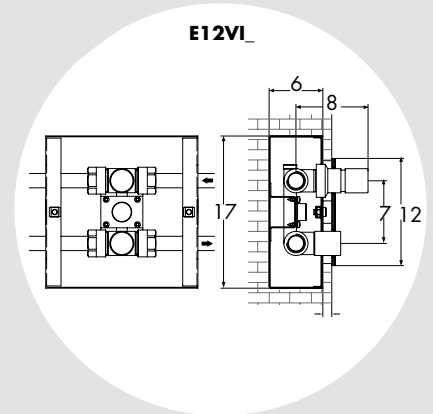

**Android IQ**

H cm	L cm	I* cm	art*	Lt*	watt $\Delta t$ 30°	watt $\Delta t$ 50°
129.0	61.8	47.3	<b>ANIQ129061_</b>	2.1	498	<b>964</b>

**Optional**



Angled Valve  
 Robinet équerre  
 Eckausführung Ventil  
 Válvula a escuadra

[BIAN] **E12SQB**  
 [CROM] **E12SQR**



Thermostatic head  
 Tête thermostatique  
 Thermostatkopf  
 Cabezal termostático

[BIAN] **TTB**  
 [CROM] **TTR**

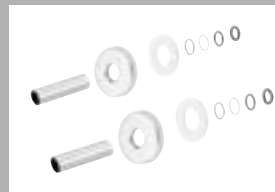

$\varnothing \leq 16$  mm  
 [BIAN] **CTB**  
 [CROM] **CTR**

$16 \text{ mm} < \varnothing > 24$  mm  
 [BIAN] **CWB**  
 [CROM] **CWR**



Towel bar  
 Porte-serviettes  
 Hsndtuchstler  
 Porta toallas

64,7 cm  
 [XLUC] **AMA65L**

art\* = item / modèle / Artikel / artículo    I\* = pipe centres / distance entre depart et retour / Achsabstand / distancia entre las conexiones  
 Lt\* = water content for each element / volume d'eau pour chaque element / Wassergehalt für Element / contenido de agua por cada elemento  
 P\* = page / page / Seite / página

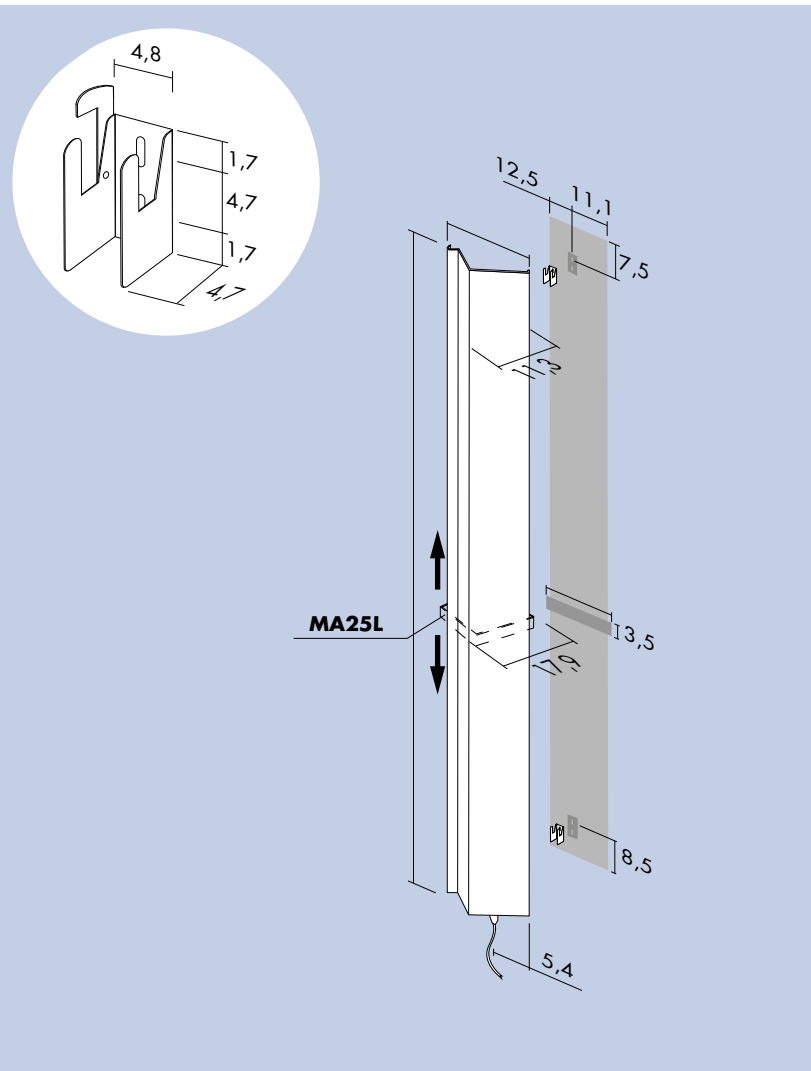

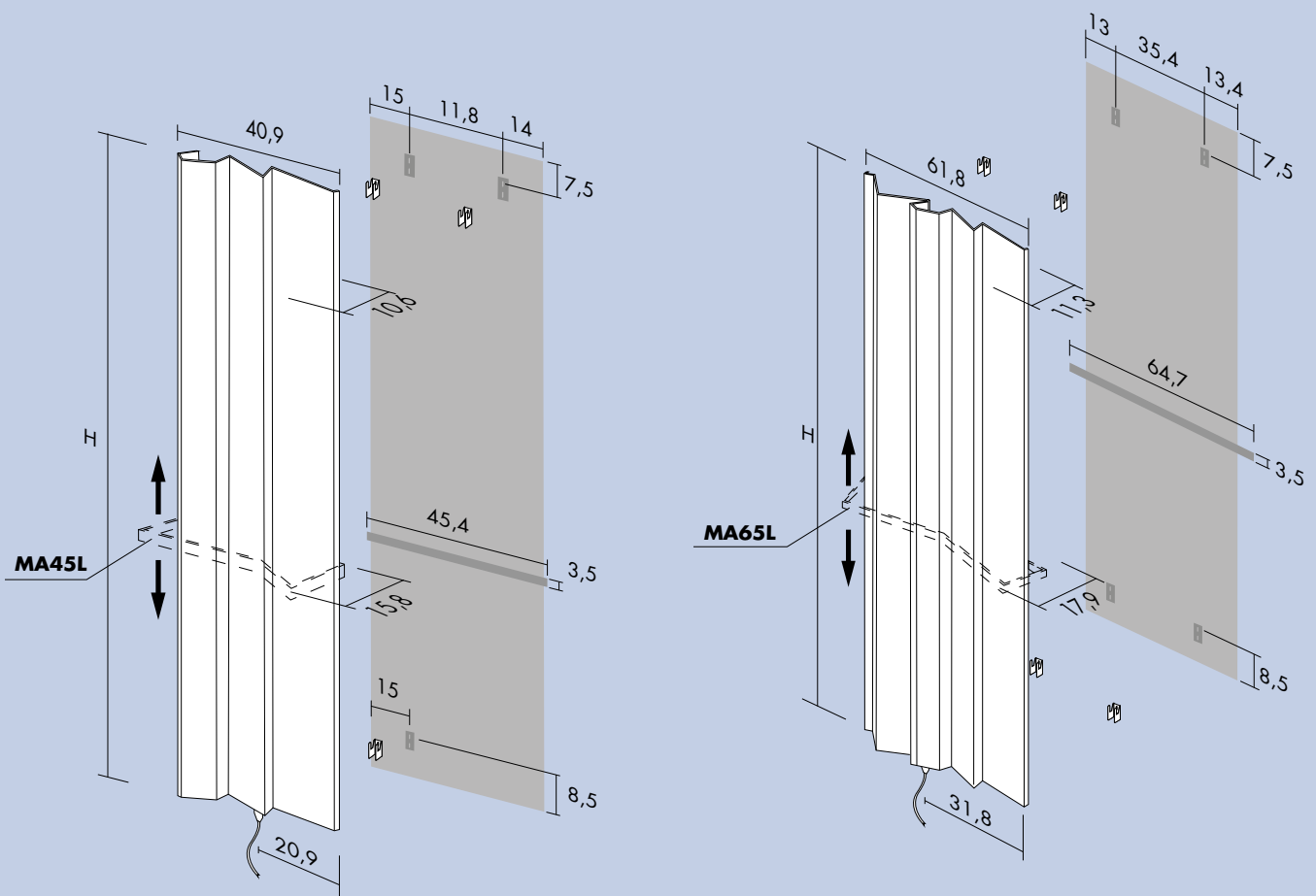

Electric with schuko plug / Version électrique avec prise schuko / Elektromodell mit schukosteckdose / Versión eléctrica con enchufe schuko

H cm	L cm	art*	watt
150.0	23.6	<b>EC ANDV150023</b>	<b>350</b>
150.0	40.9	<b>EC ANDV150040</b>	<b>600</b>
150.0	61.8	<b>EC ANDV150061</b>	<b>800</b>
180.0	23.6	<b>EC ANDV180023</b>	<b>400</b>
180.0	40.9	<b>EC ANDV180040</b>	<b>700</b>
180.0	61.8	<b>EC ANDV180061</b>	<b>900</b>
200.0	23.6	<b>EC ANDV200023</b>	<b>500</b>
200.0	40.9	<b>EC ANDV200040</b>	<b>800</b>

## Optional



Receiver  
Récepteur  
Empfänger  
Receptor

**R10**



Digital chronothermostat  
Chronothermostat digital  
Der digital Chronothermostat  
Cronotermostato digital

**T10**



25,4 cm  
[XLUC] **MA25L**  
45,4 cm  
[XLUC] **MA45L**  
64,7 cm  
[XLUC] **MA65L**



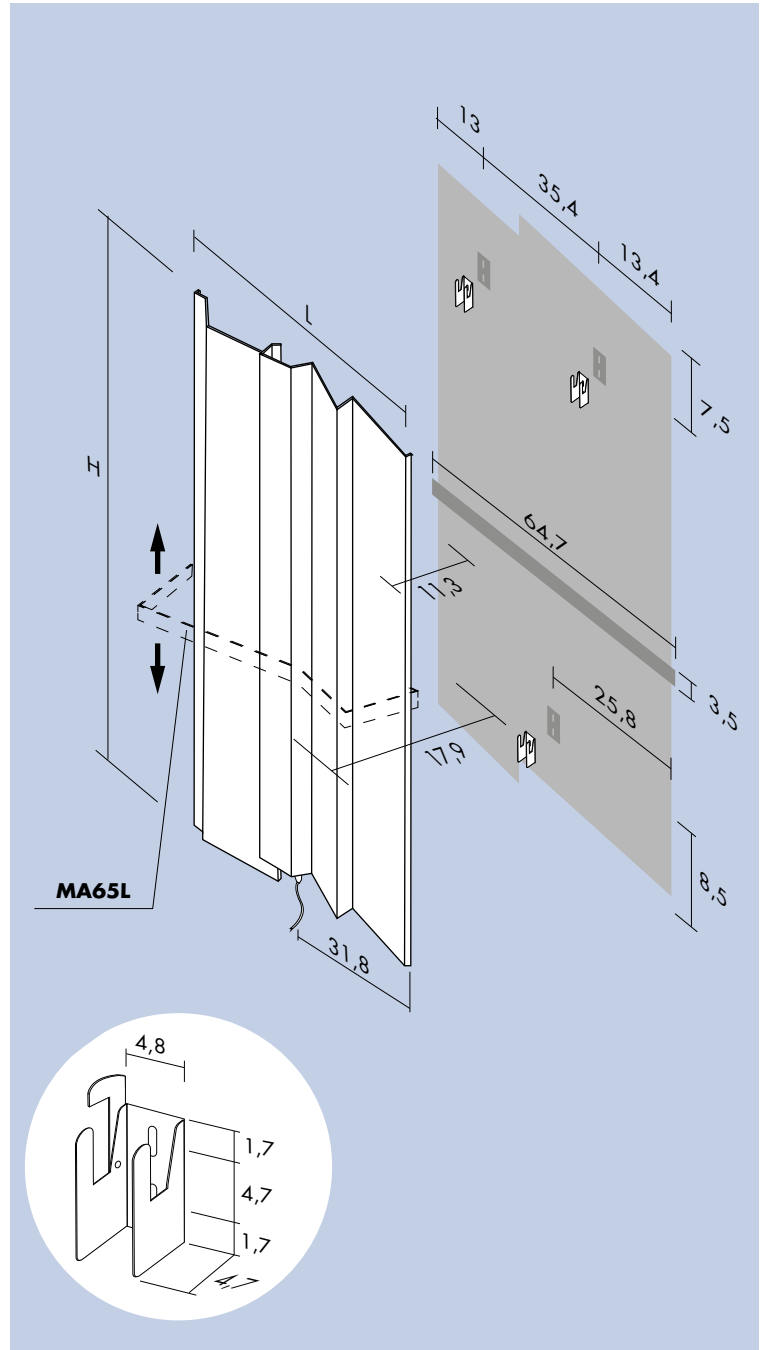
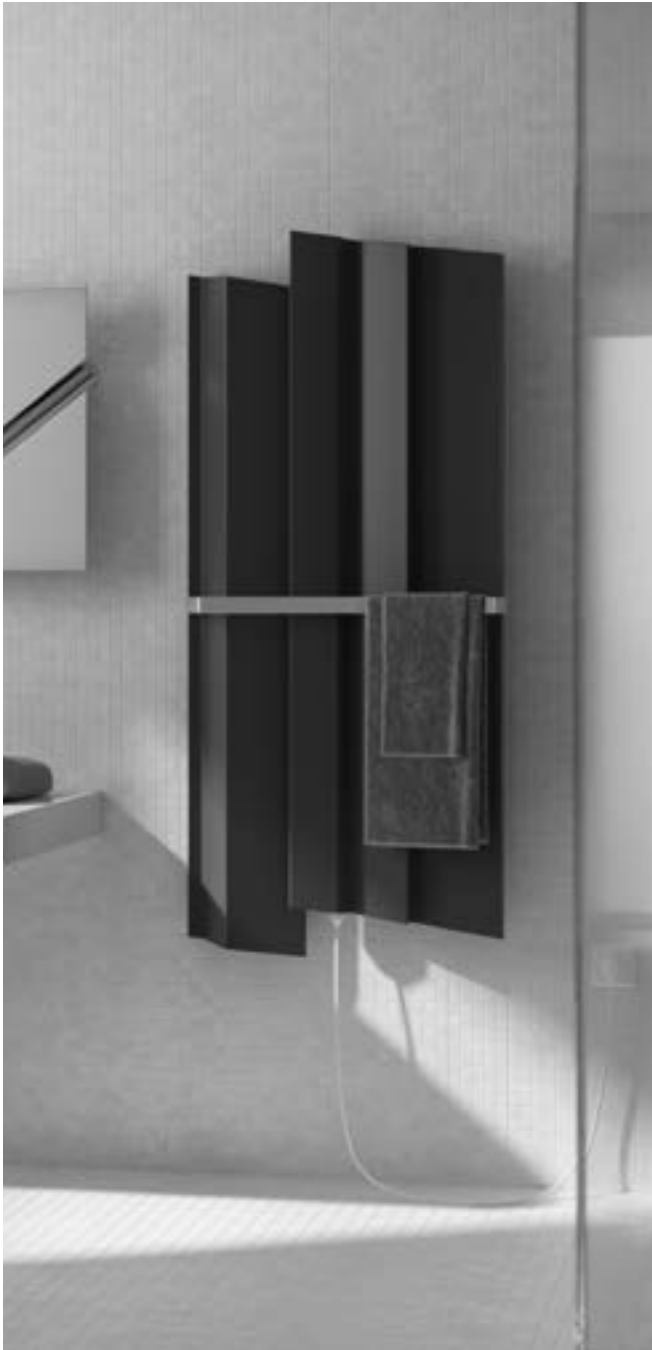

Elettrico con presa schuko

H cm	L cm	art*	watt
129.0	61.8	<b>EC ANIQ129061</b>	<b>700</b>

## Optional



Receiver  
Récepteur  
Empfänger  
Receptor

**R10**



Digital chronothermostat  
Chronothermostat digital  
Der digital Chronothermostat  
Cronothermostato digital

**T10**



Towel bar  
Porte-serviettes  
Handtuchalter  
Porta toallas

64,7 cm  
[XLUC] **MA65L**